

## Application:

CVS-SAFE4 Ceiling Dampers have been tested, approved, and classified by Underwriters' Laboratories for use in UL Fire Resistance Floor-Ceiling and Roof-Ceiling Designs as listed in the UL Fire Resistance Directory. These dampers have been approved for, but not limited to, wood joist systems incorporating gypsum wall board ceilings. Designs specifically tested pertain to UL Designs L501, L502, L503, L506, L507, L508, L512, L513, L514, L515, L516, L517, L519, L522, L523, L533, L537, L545, L581, L583 and M500 series design. New UL Ceiling designs are constantly being added. Refer to the UL Fire Resistance Directory for current approved listings. CVS ceiling dampers may be substituted into any UL design which incorporates a hinge door type damper as outlined in the Fire Resistance Directory.

## General Notes:

- Fasteners must be placed so not to interfere with the operation of the damper.
- Classified flex duct must be attached with steel clamps, plastic straps, or 18 swg minimum steel wires.
- The mounting angles (#8 Below) are to be placed such that 1/2" leg rest on the ceiling materials.
- The maximum size damper approved for this installation is 16" x 12" or 15" diameter.
- The insulating material mentioned in #3 below can optionally be gypsum secured by 4 sheet metal screws to the top of the metal box (#10) and another secured to the floor (#9) the width of the joist by damper length plus 4 inches when the damper size is not greater than 110 sq. inches. If damper size is greater than 110 sq. inches or previous option not used, then an insulating material must be supplied by CVS to fully wrap metal box (#10).

## Components:

- Wood Frame Member or Joist
- Ceiling Damper
- Insulating Material (See Note E Above)
- Grille
- Gypsum Wallboard per UL Design number
- #8 Screw(min) or 6 Penny Nail
- #8 Screw(min) or 3/16" Steel Rivet
- 1" x 1/2" x 20 ga. Steel Mounting Angle
- Floor / Roof
- Metal Box (22 ga. min., can be supplied by contractor/installer)
- Cut opening/transition in box

Figure 1

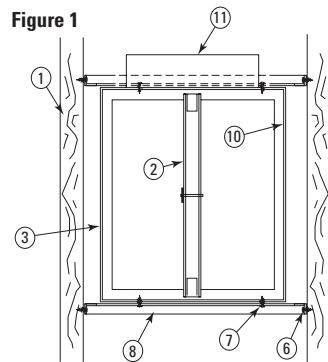

Figure 2: Less Than or Equal to 110 Sq. in.

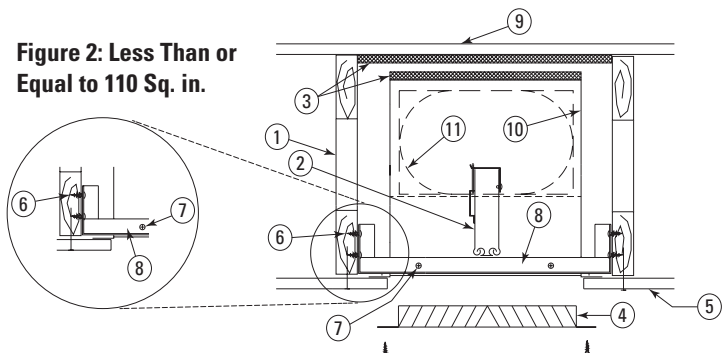
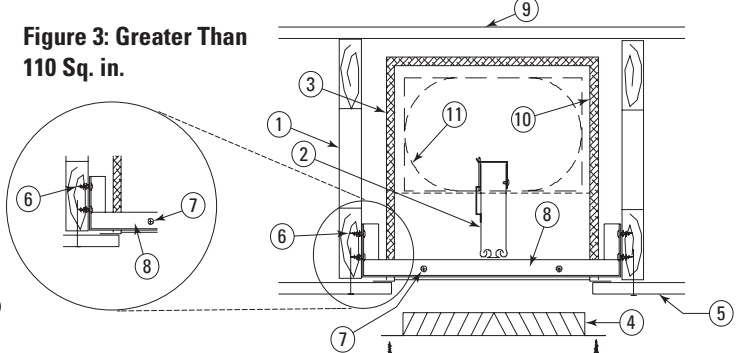

Figure 3: Greater Than 110 Sq. in.



## Installation of Ceiling Damper:

- Measure spacing between framing members. Cut angle to distance between members plus six inches. Two full lengths of 1" x 1/2" x 20 ga. steel mounting angles will be required for each damper.
- Cut a slit in the 1" leg, three inches from each end. Bend each end of the mounting angle 90°.
- Attach the bent section of one of the mounting angles to the wood framing member using #8 screws or 6 penny nails. Use a minimum of 2 fasteners per bent section (see details in Figures 2 and 3). The mounting angles are to be placed such that 1/2" leg rest on the ceiling materials.
- Attach the ceiling damper to the 1" x 1/2" mounting angle using #8 screws or 3/16" rivets. A minimum of 2 fasteners per angle on the square/rectangular damper and one fastener per angle on the round damper required (see Figure 1).
- Position the remaining mounting angle on the opposite side of the damper between the joists. Attach one of the 3" bent angle to the wood joist with two #8 screws or 6 penny nails. The mounting angles are to be placed such that 1/2" leg rest on the ceiling materials (see Figure 1).
- Attach the ceiling damper to the 1" x 1/2" mounting angle using #8 screws or 3/16" rivets. A minimum of 2 fasteners per angle on the square/rectangular damper and one fastener per angle on the round damper required.
- Attach the remaining end of the 3" bent angle to the wood joist with two #8 screws or 6 penny nails (see details in Figures 2 and 3).